

Smart 3 Channel Led Drive Voltage

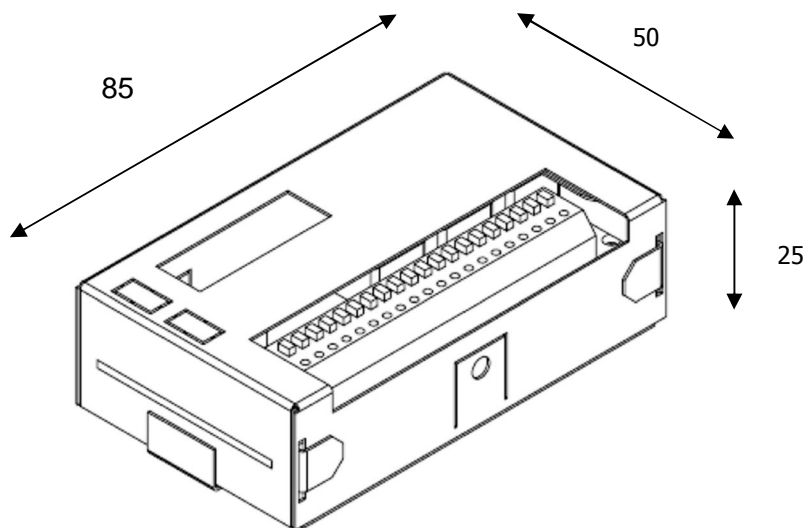

General Information :

The *Smart 3 Channel Led Drive Voltage* is a high efficient constant voltage drive for RGB led systems with common anode. It can be used in a master mode (colour change program with simple pushbutton operation or fixed outputs with dimming capabilities) or slave mode (DMX controlled).

The *Smart 3 Channel Led Drive Voltage* can control up to 3A per channel .

The Smart 3 Channel Led Drive is fitted with a metal housing in order to avoid EMC interferences and allows for easy installation either directly on a mounting panel or a DIN-rail. All wires are connected to the drive by means of easy push in connectors. The *Smart 3 Channel Led Drive Voltage* has an easy built in test facility to check the wiring of a led system.

A. Connections:

Power supply			DMX						Colour loop			Master dim		LED channels			
DC IN + 12-48V	DC IN -		+	-	0	+	-	0	LED	Button	GND	Button	Button	COM (+)	CH1 (R)	CH2 (G)	CH3 (B)

1. Power supply: 12-48Vdc

The input voltage depends on the working voltage of the applied led system.

2. DMX

Connection of \pm signal, \pm signal and signal ground. These connections are provided twice, so multiple DMX devices can be linked easily.

Up to 32 devices can be placed in a DMX512 network. If more devices are required, a DMX-splitter has to be used.

3. Colour loop

A simple push button can be connected between Button and GND to start and stop the colour loop and to switch the drive on and off.

An indication LED can be connected between LED and GND with the anode (+) on LED

4. Master dim

A simple push button can be connected to dim the LEDs and to switch the drive on and off.

5. LED channels

Connector for the LEDs. Connect the common anode of the led system to COM(+). The cathodes have to be connected to CH1(R), CH2(G) and CH3(B). For colour loops, it is recommended to connect the red LED(s) to the R-channel, the green LED(s) to the G-channel and the blue LED(s) to the B-channel.

B. DIP Switches

Speed		Auto Start				RED	GREEN	BLUE	Master	ON
1	2	3	4	5	6	7	8	9	10	
DMX 1	DMX 2	DMX 4	DMX 8	DMX 16	DMX 32	DMX 64	DMX 128	DMX 256	Slave	OFF

The drive can work in master mode or in slave mode.

1. Master mode

In master mode, the colour program can be used or every channel can be driven separately or together. The Colour loop button can be used to start and stop the colour loop and to switch the LEDs on and off. The Master dim button can be used to dim the LEDs and to switch the LEDs on and off. In master mode, the drive generates a DMX signal with red on channel 1, green on channel 2 and blue on channel 3. When more drives are operating simultaneously in master mode, then only one drive can be to master, the rest needs to be set to slave mode with DMX address 1. Only one drive can be set to master in one group of drives which operate together. If more drives in one group are set to master, risk of damage to the internal DMX chip can occur.

To select master mode, put switch 10 on.

- Colour loop

In master mode, if switches 7, 8 and 9 are off, the Drive operates in a colour loop program. The speed can be set by switches 1 and 2. The setting is as follows :

SW 1	SW2	cycle
1	1	10,5 sec
0	1	31,5 sec
1	0	52,5 sec
0	0	73,5 sec

A short push on the Colour loop button stops the loop, so a fixed colour is output. A short push again, restarts the program.

A long push (2.5 sec) on the **Colour loop button** switches the LEDs off. A short push turns the LEDs on again. The last colour and dim-level is applied. The loop keeps running or paused, after switching the LEDs on again.

If the colour loop is running, the indication LED is on. If the colour loop is stopped, the indication LED blinks. When the system is switched off , the drive will start in the last mode (running colour or fixed colour) when switched on again .

The LEDs can be dimmed and switched on and off by the **Master dim button**

If **Auto Start**(switch 3) is on, the colour loop starts immediately after power-up. If **Auto Start** is off, the output has to be started up manually by one of the switches.

If **Auto Start**(switch 3) is on, the colour loop starts immediately after power-up. If **Auto Start** is off, the output has to be started up manually by one of the switches.

- **Fixed channel(s)**

Switches 7, 8 and 9 are used to drive the channels separately or together. When one or more of the switches are on, the colour loop is stopped and the selected channel(s) are on. This function can be used to test the wiring of the led system without using any control panels .

The **Master dim button** is used to dim the LEDs and to switch the LEDs on and off.

By pushing the **Master dim button** shortly, the LEDs are switched on and off. By pushing the **Master dim button** long, the LEDs are dimmed up or down. The dim direction (up or down) is changed every time every time the button is released after a long push.

If the Drive is off, and the **Master dim button** is pushed long, the LEDs dim up from zero. If the LEDs are dimmed to zero, so the drive is off, and the **Master dim button** is pushed shortly, the LEDs are driven at maximum.

If **Auto Start**(switch 3) is on, the channels are on after power-up. If **Auto Start** is off, the channels have to be turned on manually by one of the switches.

2. Slave mode

To select slave mode, put switch 10 off.

Now the drive listens to a DMX signal. The Smart 3 Channel Led Drive is a 3 channel DMX device . The start address can be set by switches 1 to 9. The start address is the sum of the values indicated in the figure above of the switches that are on.

For example, to connect two 3 channel Drives put one Drive in master mode (switch 10 on) and the other in slave mode and DMX address 1 (only switch 1 on).

When the DMX signal falls away , all channels will switch to full on after approximately 2 seconds .

C. Technical data

Version:

12Vdc . 48Vdc PWM

Input:

12Vdc . 48Vdc

Output:

12Vdc . 48 V DC PWM , 3A per channel

Network:

DMX-512

Features:

Colour loop program

Fixed colours

Master dim pushbutton input

Colour program pushbutton input

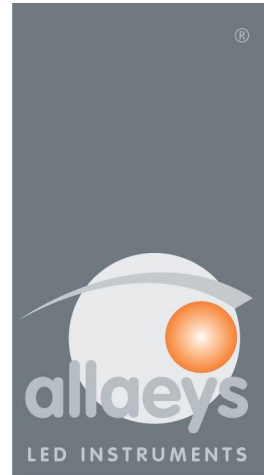

www.allaEys.com